

# RICCAR®

## VIBRANCE

Owner's Manual  
for all Vibrance models





<b>IMPORTANT SAFETY INSTRUCTIONS</b> .....	2
Polarization instructions .....	3
Description of the vacuum .....	4
Before using your Vibrance the first time .....	6
<b>Operation</b>	
Unwinding the power cord .....	7
Turning vacuum on / off .....	8
Vacuuming carpet .....	9
Vacuuming hard surfaces .....	9
Carpet height adjustment .....	9
Vacuuming under furniture .....	10
Carrying the vacuum .....	11
<b>Attachment Cleaning</b>	
Wand cleaning .....	12
Cleaning tools .....	13
Adjusting the suction power .....	14
Optional cleaning tools .....	15
Connecting attachment hose .....	16
<b>Maintenance and Care</b>	
When to change the vacuum bag and clog indicator .....	17
Replacing the vacuum bag .....	18
When to change the filters .....	19
Replacing the filters .....	19
Removing and reinstalling bottom plate .....	21
Replacing the agitator belt .....	22
Replacing the headlight bulb .....	24
Edge cleaning .....	24
Annual checkup reminder .....	24
<b>Problem Solving Guide</b>	
Unclogging nozzle and hose .....	25
Thermal motor protection .....	26
Trouble shooting .....	27
How to contact your Authorized Retailer .....	27
Visit Riccar on-line .....	27
<b>Warranty</b> .....	28

# **IMPORTANT SAFETY INSTRUCTIONS**

---

When using an electrical appliance, basic precautions should always be followed, including the following:

## **READ ALL INSTRUCTIONS BEFORE USING THIS APPLIANCE**

**WARNING:** The manufacturer cannot accept responsibility for damage caused when the appliance is not used according to the instructions, or for uses other than those for which it was intended.

To reduce the risk of fire, electric shock or injury:

- Do not leave appliance when plugged in. Unplug from outlet when not in use and before servicing.
- Do not handle plug or appliance with wet hands.
- **WARNING: ELECTRIC SHOCK COULD OCCUR IF USED OUTDOORS OR ON WET SURFACES.**
- Do not put any object into openings. Do not use with any opening blocked; keep free of dust, lint, hair and anything that may reduce air flow.
- Do not allow to be used as a toy. Close attention is necessary when used by or near children.
- Keep hair, loose clothing, fingers and all parts of body away from openings and moving parts.
- Use only as described in this manual. Use only manufacturer's recommended attachments.
- Do not pick up anything that is burning or smoking, such as cigarettes, matches or hot ashes.
- Do not use with damaged cord or plug. If appliance is not working as it should, has been dropped, damaged, left outdoors, or dropped into water, return it to your Authorized Retailer for service.
- Do not use without vacuum bag and/or filters in place.
- Turn off all controls before unplugging.
- Use extra care when cleaning on stairs.
- Do not pull or carry by cord, use cord as a handle, close a door on the cord, or pull cord around sharp edges or corners. Do not run appliance over cord. Keep cord away from heated surfaces.
- Do not use to pick up flammable or combustible liquids, such as gasoline, or use in areas where they may be present.
- Do not unplug by pulling on cord. To unplug, grasp the plug, not the cord.
- Do not attempt to service the unit while appliance is plugged in.

## **SAVE THESE INSTRUCTIONS.**

# Polarization Instructions

## POWER CORD, 2-WIRE POLARIZED CORD

**Household Models: VIB, VIBUSA, VIBCLNT, VIBCL, VIBS, VIBD, VIBPNT & VIBP**

To reduce the risk of electric shock, this product is equipped with a polarized alternating current line plug (a plug having one blade wider than the other). This plug will fit into the power outlet only one way. This is a safety feature. If you are unable to insert the plug fully into the outlet, try reversing the plug. If the plug should still fail to fit, contact a qualified electrician to replace the obsolete outlet. Do not defeat the safety purpose of the polarized plug.

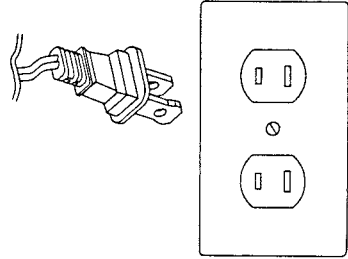

## Grounding Instructions

**Commercial Models: VIBCNT & VIBC**

This vacuum cleaner must be grounded. If it should malfunction or break down, grounding provides a path of least resistance for electric current to reduce the risk of electric shock. This vacuum cleaner is equipped with a cord having an equipment-grounding conductor and grounding plug. The plug must be plugged into an appropriate outlet that is properly installed and grounded in accordance with all local codes and ordinances.

This vacuum cleaner is for use on a nominal 120-volt circuit and has a ground plug (see illustration). Make sure the vacuum is connected to an outlet having the same configuration as the plug. No adapter should be used with this vacuum.

**WARNING** – Improper connection of the equipment-grounding conductor can result in the risk of electric shock. Check with a qualified electrician or service person if you are in doubt as to whether the outlet is properly grounded. Do not modify the plug provided with the vacuum – if it will not fit the outlet, have a proper outlet installed by a qualified electrician.

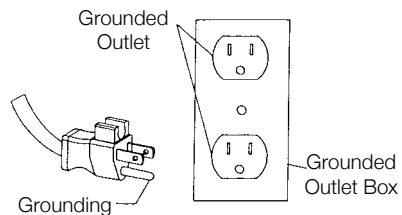

# Description of the vacuum

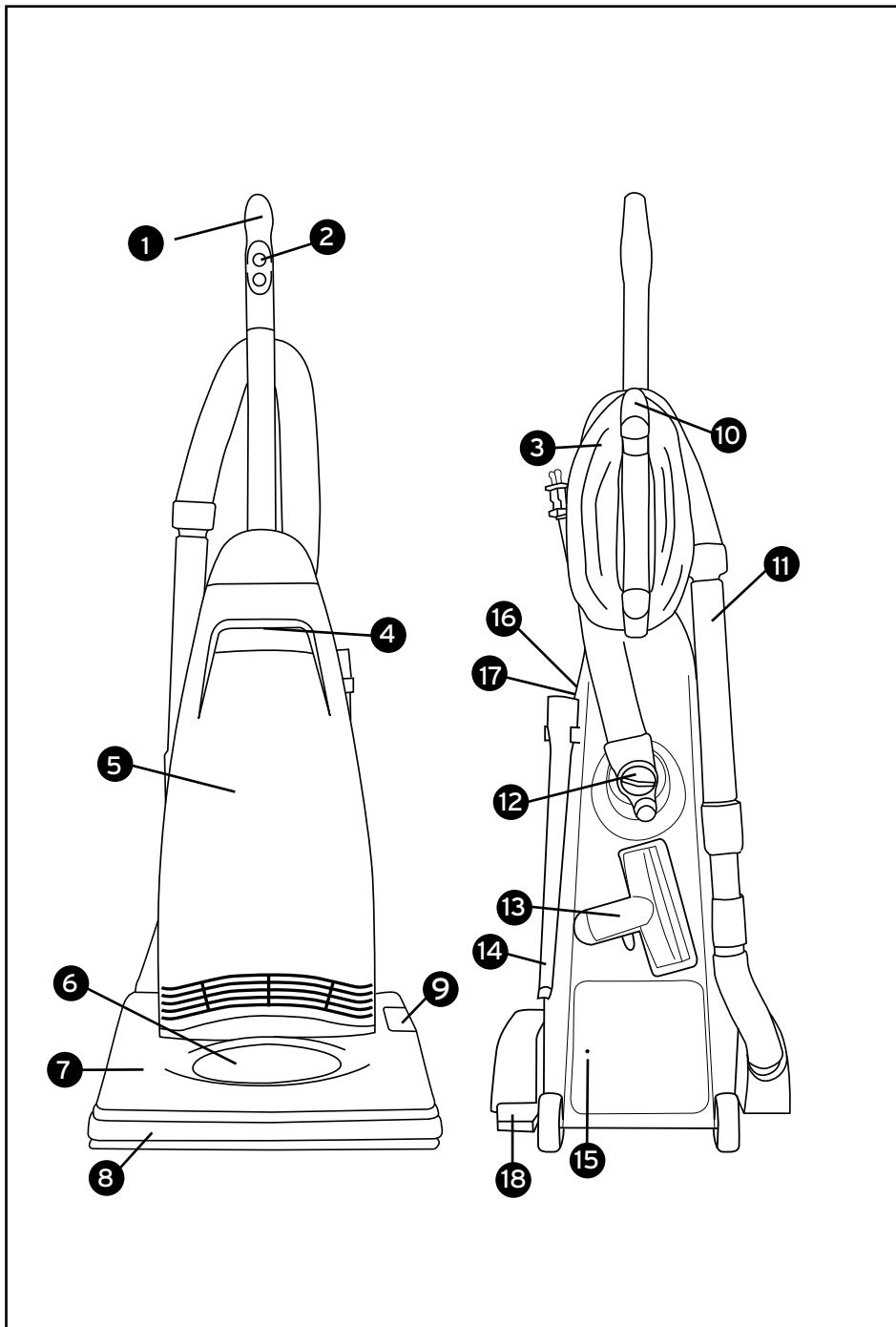

# Description of the vacuum

---

- 1 Ergonomic handle
- 2 Main on / off power switch  
(for models VIB, VIBS, VIBD, VIBPNT, VIBP, VIBCNT & VIBC)
- 3 Power Cord
- 4 Carrying handle
- 5 Bag compartment cover (to replace vacuum bag)
- 6 Xenon headlight
- 7 Vacuum nozzle
- 8 Furniture guard
- 9 Carpet / floor selector (for models VIB, VIBUSA, VIBPNT & VIBP)
- 10 Quick release cord hook
- 11 Fast Task™ tools (for models VIB, VIBUSA, VIBCL, VIBS, VIBD, VIBP & VIBC)
- 12 Suction control dial
- 13 Combination dusting / upholstery brush  
(for models VIB, VIBUSA, VIBCL, VIBS, VIBD, VIBP & VIBC)
- 14 Crevice tool (for models VIB, VIBUSA, VIBCL, VIBS, VIBD, VIBP & VIBC)
- 15 Thermal reset button
- 16 Full bag / clog indicator (for models VIB, VIBD, VIBPNT, VIBP, VIBCNT & VIBC)
- 17 Main on / off power switch (for models VIBCLNT, VIBCL & VIBUSA)
- 18 Handle release pedal

# Before using your Vibrance for the first time

## Attaching the handle to the vacuum

The vacuum cleaner and the handle are packed separately.

- After first removing the handle screw, position the handle behind the vacuum cleaner and level with the top of the unit. Hold the power cord down and away from the vacuum while the handle is being attached. Make sure that the switch on the handle is positioned toward the front of the vacuum cleaner.
- On the bottom of the handle are two “T-shaped” rails that slide forward onto two guides located on the top of the vacuum cleaner. Line up the handle so that the “T” rails will slide into the guides and push the handle forward.
- Insert the handle screw and tighten securely.
- Turn the upper cord storage hook to the upright position and wind the power cord around the cord storage hooks when storing the vacuum cleaner.

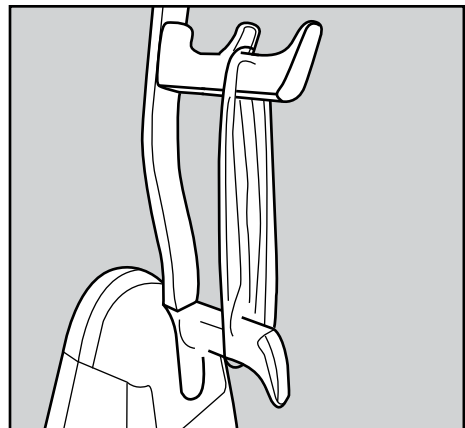
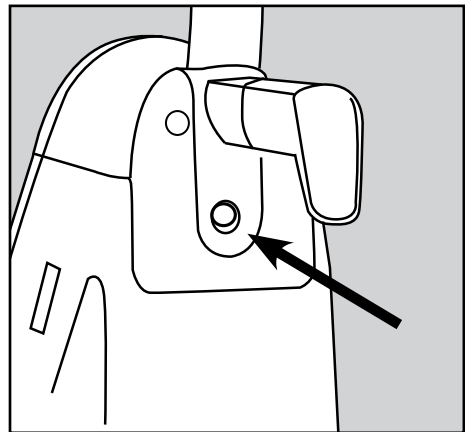
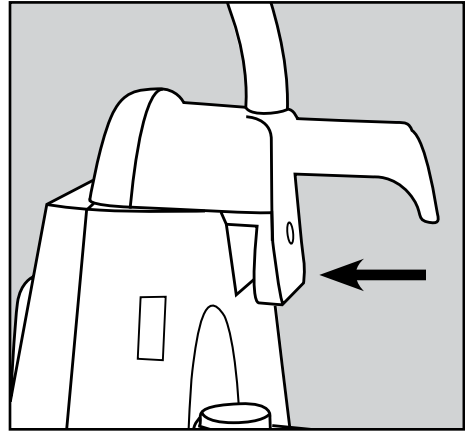



## Unwinding the power cord

- The upper cord hook rotates to allow for quick access to the power cord.

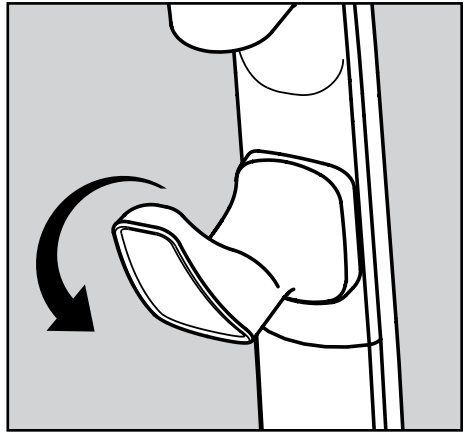

# Operation

---

## On / Off switch

**Models: VIB, VIBS, VIBD, VIBPNT, VIBP, VIBCNT & VIBC**

- To start the vacuum cleaner, flip the “on / off” switch located on the handle to the “on” position.
- To stop the vacuum cleaner, flip the “on / off” switch to the “off” position.
- Turn the vacuum cleaner off before unplugging from electrical outlet.

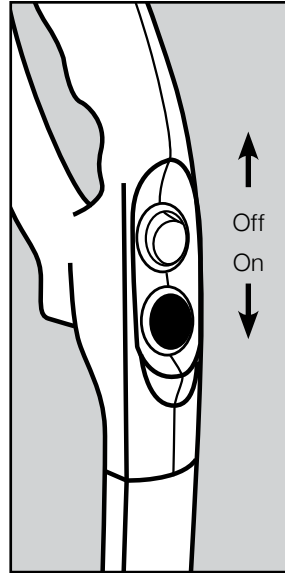

## On / Off switch

**Models: VIBUSA, VIBCLNT & VIBCL**

- To start the vacuum cleaner, flip the “on / off” switch located on the side of bag compartment to the “on” position as indicated on the switch.
- To stop the vacuum cleaner, flip the “on / off” switch to the “off” position as indicated on the switch.
- Turn the vacuum cleaner off before unplugging from electrical outlet.



## Vacuumping carpet

**Models: VIB, VIBUSA, VIPNT & VIBP only**

- For carpet cleaning, slide the carpet / floor selector toward the back of the nozzle so that it reads “carpet”.

## Vacuumping hard surfaces and using tools

**Models: VIB, VIBUSA, VIPNT & VIBP only**

- To prevent brushroll from spinning when cleaning bare floors or using tools, slide the carpet / floor selector toward the front of the nozzle so that it reads “floor & tools”.

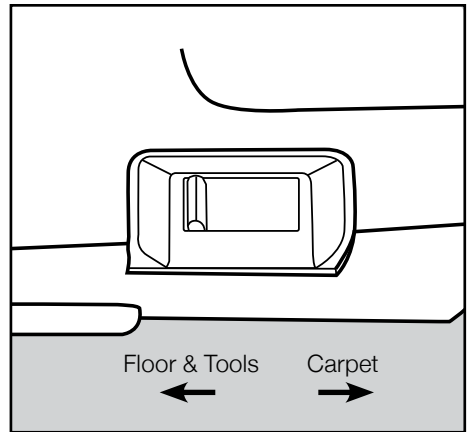

## Carpet height adjustment

Your Riccar upright vacuum cleaner is designed with an automatic self-adjusting rug nozzle. No manual adjustments are required. The height of the rug nozzle is instantly and automatically adjusted to carpet pile height. This self adjusting feature allows the rug nozzle to float evenly over all carpet pile surfaces.

# Operation

---

## Vacuuming under furniture

Your Riccar Vibrance will lay flat on the floor for effective cleaning under beds and tables.

- Press the foot pedal release once for normal vacuum cleaning.
- Press the foot pedal release a second time to enable the vacuum to lay flat on the floor.

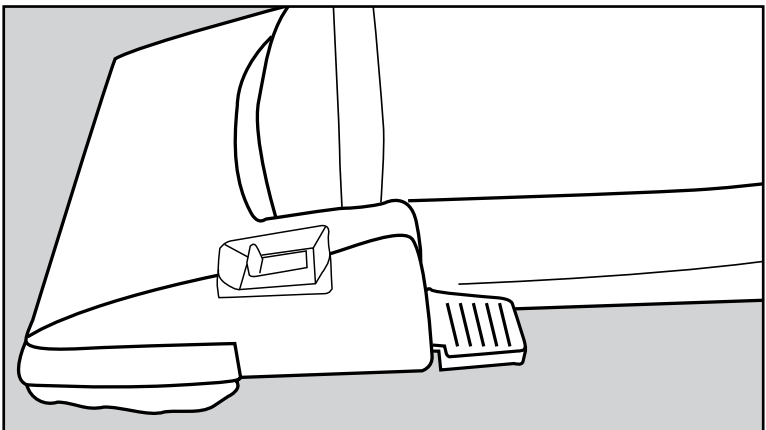
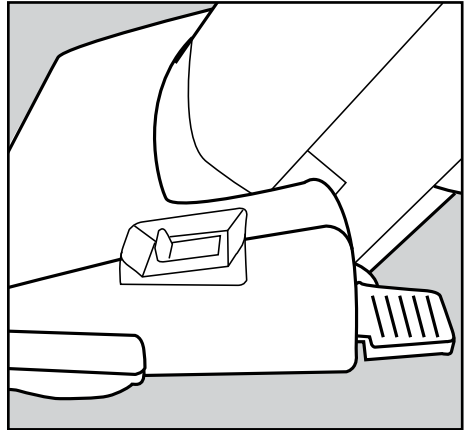
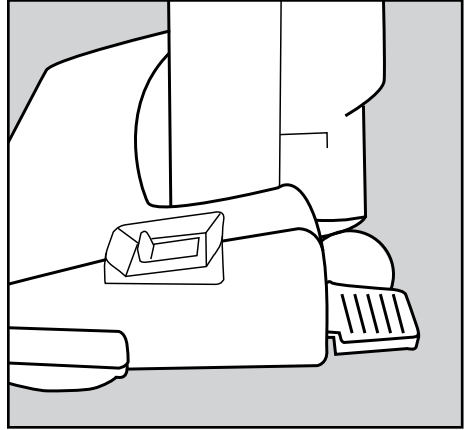

## Carrying the vacuum

To safely transport your vacuum, especially when carrying the vacuum up and down stairs, use the carry handle.

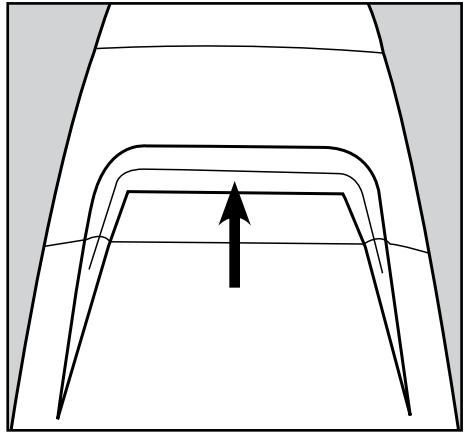

# Attachment Cleaning

---

## Wand cleaning

**Models: VIB, VIBUSA, VIBCL, VIBS, VIBD, VIBP & VIBC**

With the on-board cleaning tools and vacuum wand, your Riccar Vibrance becomes a comprehensive cleaning system. The models equipped with on-board tools include an upholstery tool, dusting brush, crevice tool, extension wand and stretch hose.

- Remove the telescopic wand from the body of the vacuum. Unlock the wand collar (located on end of wand), extend the wand and re-lock the wand collar.

NOTE: The wand collar locking rotation is marked with arrows on the wand. The wand collar lock and unlock functions require only 1/2 turn of the collar.

NOTE: You can connect any of the cleaning tools to the end of the extension wand(s) and twist for a secure fit. To remove the cleaning tool from the extension wand(s), simply twist and pull apart.

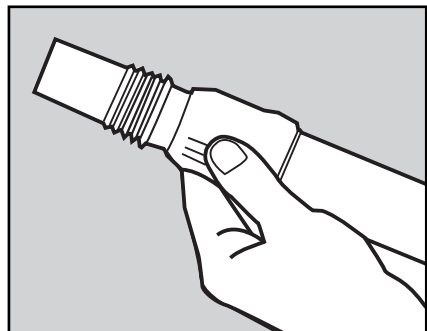
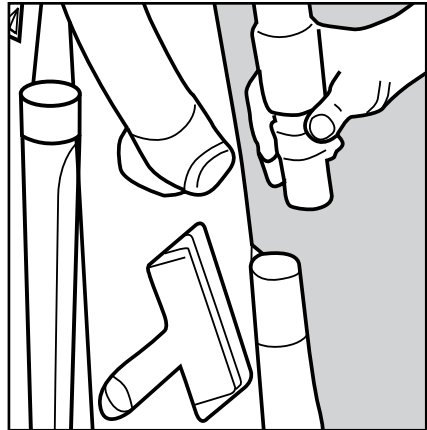

# Attachment Cleaning

## FastTask™ Cleaning tools

**Models: VIB, VIBUSA, VIBCL, VIBS, VIBD, VIBP & VIBC**

Your vacuum is equipped with a dusting brush, upholstery brush and crevice tool. Other tools are available at your Authorized Riccar Retailer.

- Remove the cleaning wand from the vacuum and turn the carpet / floor selector to the “floor & tools” position (VIBP model only, see page 9).
- Insert any of the tools onto the end of the wand.

### Dusting brush:

Ideal for table tops, shelves, blinds or hard surface floors.

### Upholstery tool:

Ideal for soft surfaces like chairs and couches. Remove the dusting brush clip for upholstery cleaning.

### Crevice tool:

Ideal for tight places like between seat cushions or corners.

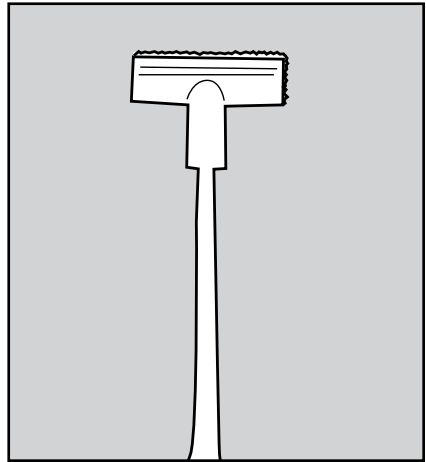

Wand with Dusting Tool

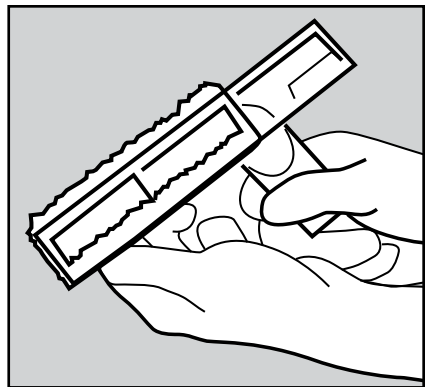

Dusting/Upholstery Tool

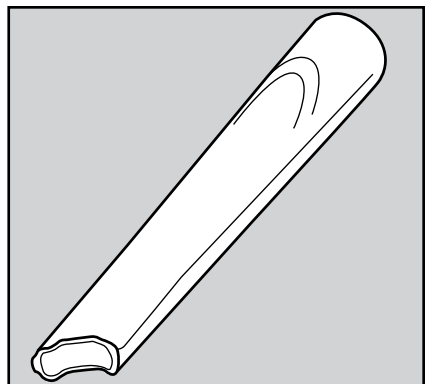

Crevice Tool

# Attachment Cleaning

---

## Adjusting the suction power for tool cleaning

On the back of the vacuum, locate the suction control dial and turn it to the desired position. This reduces the suction power coming through the hose. Close the suction control dial when finished to restore full suction power.

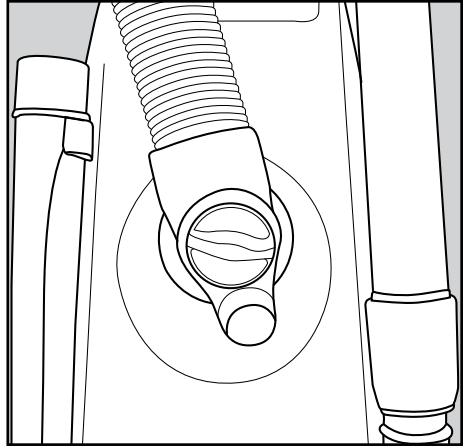



## Optional cleaning tools

All Riccar Vibrance vacuum cleaners offer an attachment port that enables you to insert optional cleaning tools (available through your Riccar Retailer). Should you have carpeted stairs, for example, it is highly recommended to use one of the two kits pictured, since each offers either a 12- or 15-foot hose for safe stair cleaning. These kits are effective overall cleaning tools to address some of the hard to reach areas of your home or car. Talk to your Riccar Retailer to see which tools might be beneficial for your home.

### Deluxe Attachment Set (RDAK1)

1. 12-foot hose
2. Curved wand
3. Extension wand (2 pieces)
4. Dusting brush
5. Crevice tool
6. Upholstery tool
7. Upholstery brush insert
8. Deluxe floor brush

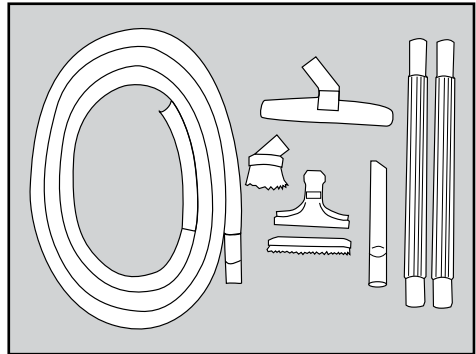

### Deluxe Attachment Set (RDAK15)

1. 15-foot hose
2. Curved wand
3. Deluxe floor brush

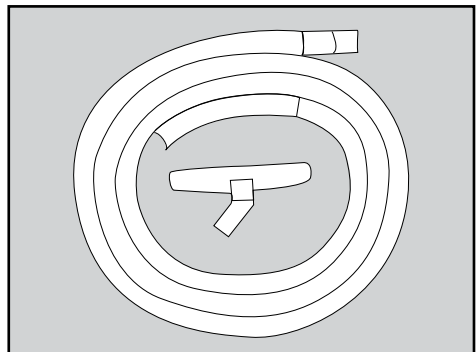

# Attachment Cleaning

---

## Connecting the attachment hose to the vacuum cleaner

Pull out and open the suction control dial by turning the lid located on the back of the vacuum cleaner. Insert the soft, rubber end of the hose into the cleaning attachment opening. Push in while twisting the hose end to ensure the hose is fastened securely.

NOTE: You can connect any of the cleaning tools to the end of the extension wand(s) and twist for a secure fit. To remove the cleaning tool from the extension wand(s), simply twist and pull apart.

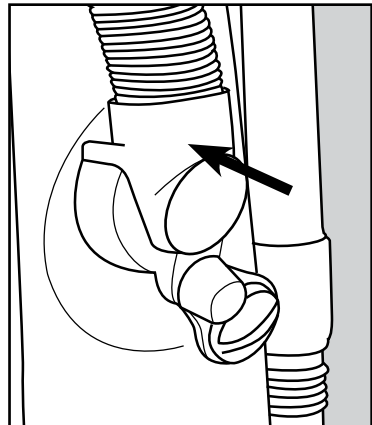

## WARNING

**Models: VIBCLNT, VIBCL,  
VIBS, VIBD, VIBCNT & VIBC**

There is no way to turn the brushroll off. Therefore, when using the cleaning tools it is important to keep your Riccar vacuum from running in the same spot for a period of time, as carpet or flooring damage could result. If you need to keep the vacuum in the same spot for a period of time, such as at the base of the stairs when cleaning the stairs, place something, like a flattened cardboard box, under the vacuum to prevent damage to the floor.

**When to change the vacuum bag and full bag indicator light**  
**Models: VIB, VIBD, VIBPNT, VIBP, VIBCNT & VIBC**

The full bag indicator light is designed to show when the bag is full or when there is a clog in the vacuum.

The system measures airflow and alerts the user when airflow is significantly reduced – most commonly from full bags and clogs.

The light could also come on when vacuuming fine powders such as flour or drywall dust. These materials can quickly block the bag pores, significantly reducing airflow before the bag appears to be full. The vacuum bag should still be changed.

The light could also come on during attachment cleaning.

**Note:** The vacuum bags are disposable and intended to only be used once. Do not attempt to reuse as suction and filtration performance would be greatly reduced.

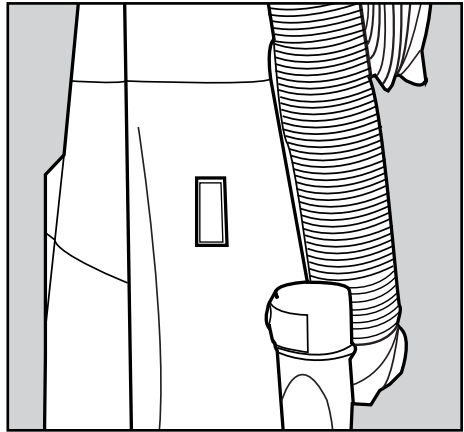

# Maintenance and Care

---

## Replacing the vacuum bag

- Open the bag compartment lid.
- Remove vacuum bag by pulling bag collar off the bag holder.
- Attach the new vacuum bag onto the bag holder.
- Tuck the bag corners into the vacuum before replacing the bag compartment lid.
- Replace lid and press onto vacuum until it snaps into place.

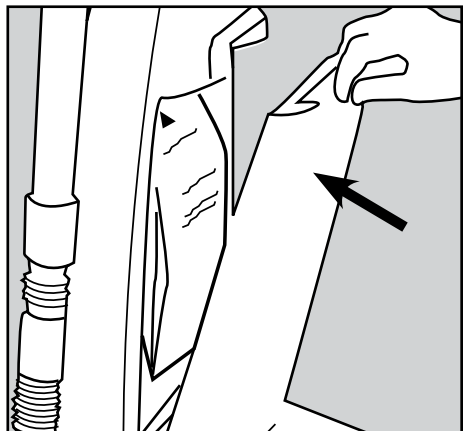
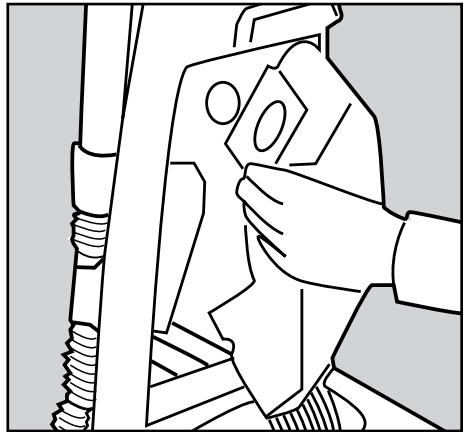
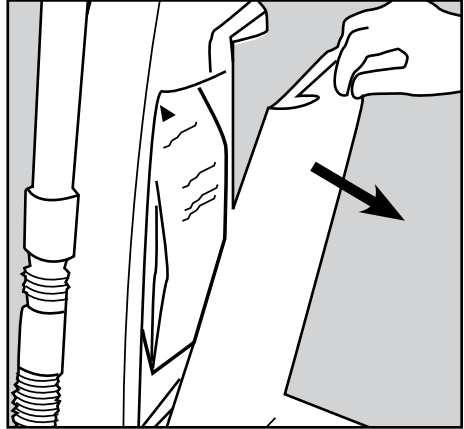

## When to change filters

At minimum, it's recommended to replace the filters once a year or after using twelve vacuum bags, whichever comes first.

If someone in your household is highly sensitive to airborne allergens, it is recommended to change the filter set after every six vacuum bags.

## Replacing the HEPA post filter Models: VIBPNT & VIBP

- Open the bag compartment lid and locate the post filter on the inside base of the cover.
- Remove the used filter and throw away.
- Press new HEPA post filter into place on the inside base of cover.
- Close the bag compartment lid.

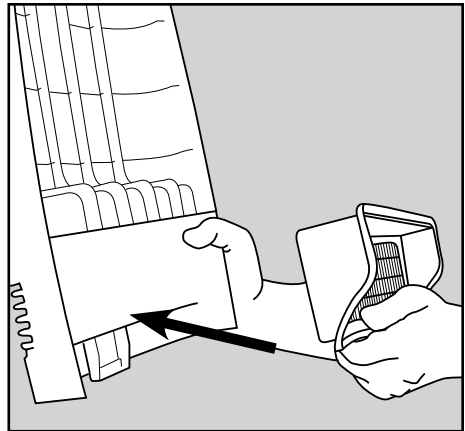

## Replacing the electrostatic or foam post filter Models: VIBCLNT, VIBCL, VIBS, VIBD, VIBCNT, VIBC, VIB & VIBUSA

- Open the bag compartment lid and locate the post filter on the inside base of the cover.
- Remove used filter and throw away.
- When inserting the new electrostatic or foam post filter, align new filter over the strips and press securely into place.
- Close the bag compartment lid.

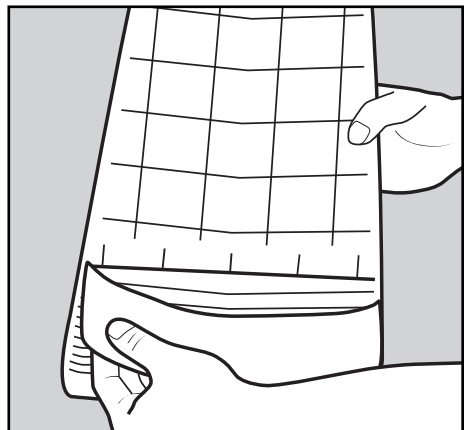

NOTE: Post filters cannot be washed.

# Maintenance and Care

## Replacing the secondary filter

The secondary filter protects the motor from dust and dirt. Before installing a new vacuum bag, check the filter. Accumulated dirt in the bag compartment will be collected on this filter and may restrict motor performance when the filter becomes dirty.

- Open the bag compartment lid and locate the secondary filter on the bottom of the bag compartment.
- Remove secondary filter from the bottom of the bag compartment.
- The foam secondary filter can be washed and reused. If washed, make sure the filter is completely dry before reinstalling.

**The charcoal secondary filter cannot be reused (models VIBPNT & VIBP).**

Remove and throw away the used charcoal secondary filter.

- Insert the new filter by sliding it under the bag support.
- Close the bag compartment lid.

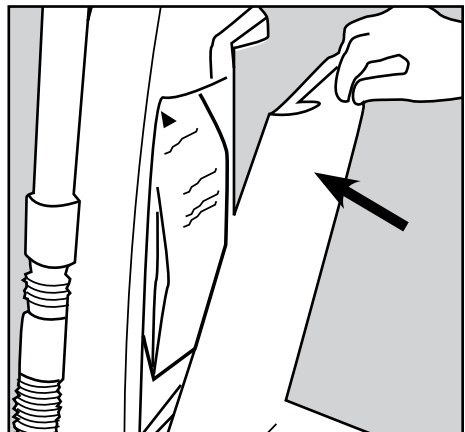
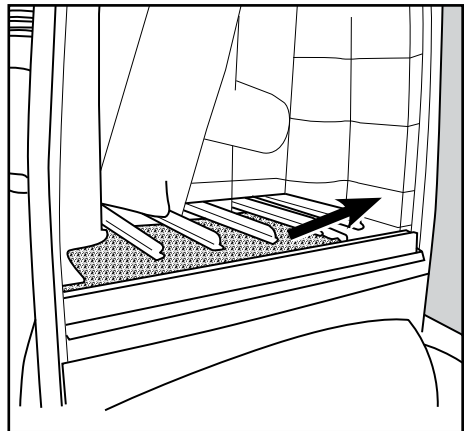
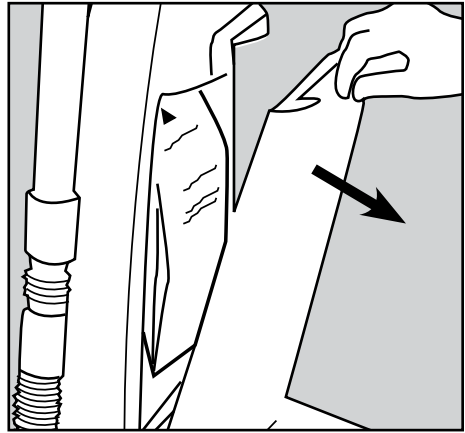

### Removing and reinstalling bottom plate

**CAUTION:** Disconnect the vacuum cleaner from the electrical outlet before removing the bottom plate.

- Depress handle release pedal twice and place the vacuum cleaner in the low position.
- Turn vacuum cleaner over, exposing the underside.
- Slide locking latch to the right.
- Press tabs inward on each side and pull bottom plate off.
- Reinstall by placing lower edge of bottom plate along lower edge of nozzle. Snap plate into place. Slide locking latch to the left to secure.

**NOTE:** To ensure maximum cleaning efficiency, the condition of the belt should be checked regularly. If belt is stretched, cracked or if excessive slipping is occurring, replace the belt.

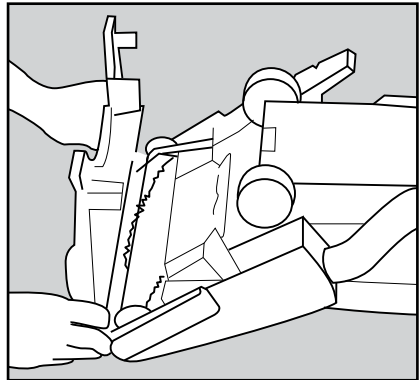
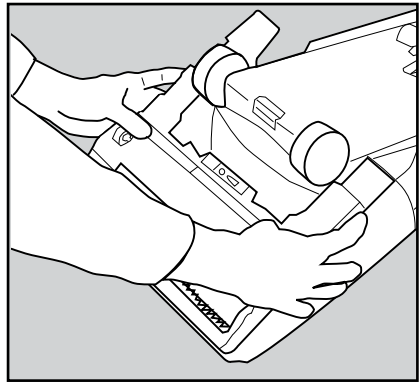
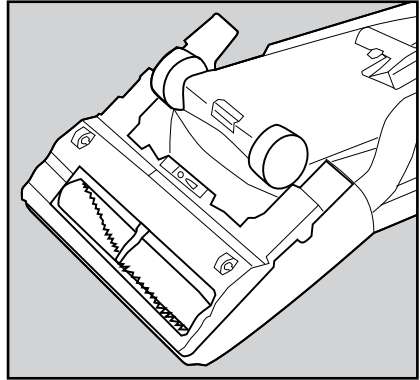

# Maintenance and Care

---

## Replacing the agitator belt

**Models: VIBCLNT, VIBCL, VIBS, VIBD, VIBCNT, VIBC, VIB & VIBUSA**

NOTE: To ensure maximum cleaning efficiency, the condition of the belt should be checked regularly. If belt is stretched, cracked or if excessive slipping is occurring, replace the belt.

- Disconnect the vacuum cleaner from the electrical outlet.
- Turn the unit over and remove the bottom plate (See "How to Install Bottom Plate").
- Remove agitator and worn or broken belt.
- Loop the new belt around the motor drive shaft and the agitator pulley.
- Reinstall the agitator into the housing while making sure that the positioning fork faces down and straddles the support guide.
- Rotate agitator pulley, making sure that the belt is not twisted.
- Reinsert the vented support fitting. Reinstall bottom plate (See "How to Install Bottom Plate").

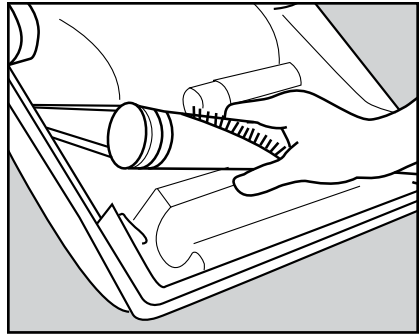
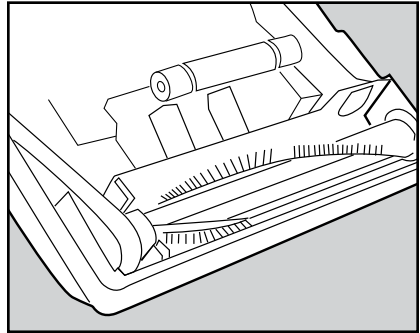



## Replacing the agitator belt

**Models: VIB, VIBUSA, VIBPNT & VIBP**

NOTE: To ensure maximum cleaning efficiency, the condition of the belt should be checked regularly. If belt is stretched, cracked or if excessive slipping is occurring, replace the belt.

- Disconnect the vacuum cleaner from the electrical outlet.
- Turn the unit over and remove the bottom plate (See "How to Install Bottom Plate").
- Move carpet / floor selector to the "floor & tools" position.
- Rotate belt so that the linkage rod can be removed. Slide linkage rod out and move the carpet / floor selector to "carpet" position and let rod rest behind brush roll compartment.
- Remove agitator and worn or broken belt.
- Loop the new belt around the motor drive shaft and the agitator pulley.
- Reinstall the agitator into the housing while making sure that the positioning fork faces down and straddles the support guide.
- Reinstall linkage rod by moving carpet / floor selector to the "floor" position.
- Rotate belt away from linkage rod, then install linkage rod into agitator.
- Rotate agitator pulley, making sure that the belt is not twisted.
- Reinsert the vented support fitting. Reinstall bottom plate (See "How to Install Bottom Plate").

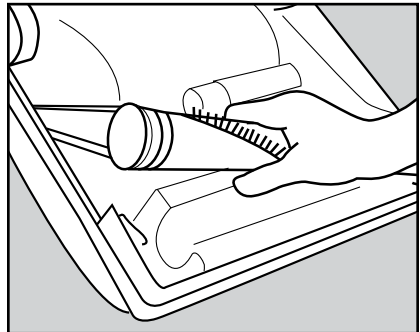
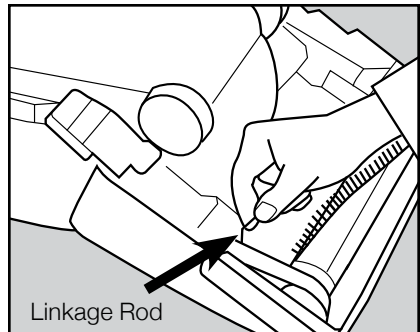
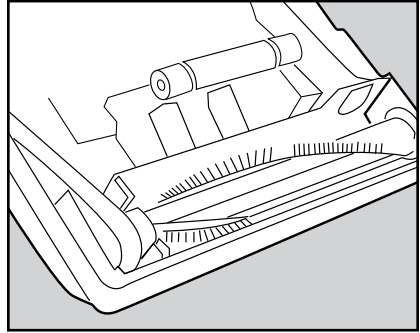

# Maintenance and Care

---

## Replacing the headlight bulb

CAUTION: Disconnect the vacuum cleaner from the electrical outlet before replacing bulb.

- Remove bottom plate (See “Removing and reinstalling bottom plate”).
- Remove the headlight bracket by pulling upward on bracket. To remove the light bulb, pull it straight out of the socket. To install new bulb, simply push it straight into the socket for a secure fit. Reinsert bracket back into nozzle.
- Reinstall bottom plate (See “Removing and reinstalling bottom plate”).

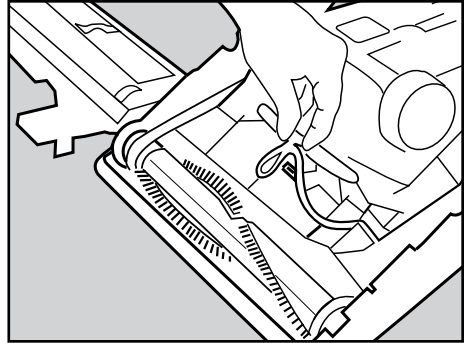

## Edge cleaning

The edge cleaning feature provides for improved cleaning of carpets near walls and stationary furniture. For maximum edge cleaning, place the right side of the nozzle against the wall or furniture.

## Annual checkup reminder

To keep your vacuum in peak operating condition, it is recommended you bring your vacuum to your Authorized Riccar Retailer for an annual checkup. Your Retailer will conduct a comprehensive examination to ensure your vacuum is in top operating condition.

## Unclogging nozzle and hose

**CAUTION:** Disconnect the vacuum cleaner from the electrical outlet before cleaning nozzle housing.

The nozzle hose, located on the back of the vacuum, carries the dirt from the nozzle to the vacuum bag. The hose also functions as the attachment cleaning hose. First check to see that a bag is installed or that the bag has not broken open.

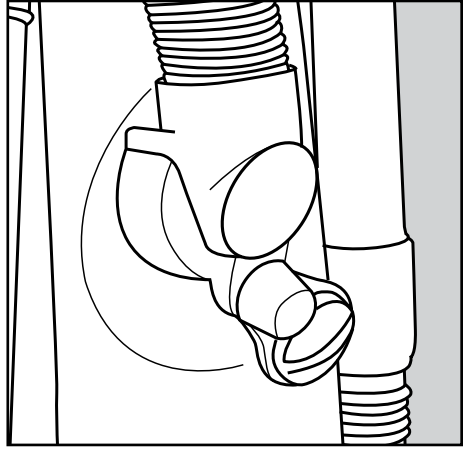

## If the hose should become clogged

- Pull out and turn the lid of the cleaning attachment opening. Remove the clog or blockage.
- Remove the hose cuff from the nozzle inlet and check for clog.
- Turn unit over and remove bottom plate (See “Removing and reinstalling bottom plate”). Check the nozzle inlet tube for obstructions. Clear tube and reinstall the bottom plate.

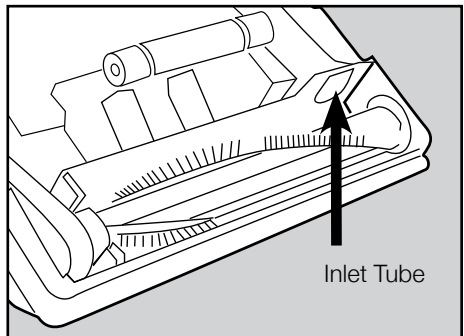
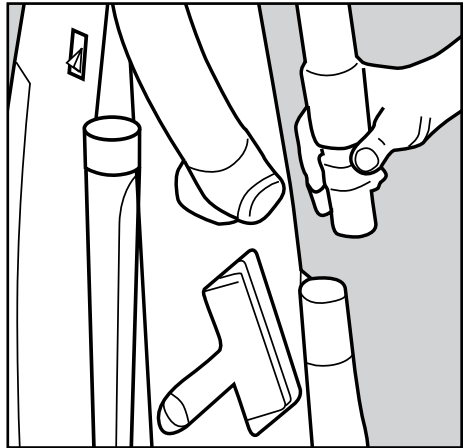

# Problem Solving Guide

## Thermal motor protection

Your Vibrance is equipped with a safeguard to recognize when the vacuum heats up and shuts itself down to protect your vacuum cleaner. Note that when this happens, the headlight is still on but the motor shuts off. Common reasons why a vacuum may overheat include operating a vacuum with a full bag or when there is a clog in the vacuum.

- Unplug the vacuum.
- Inspect your vacuum for a full bag condition or a hose clog and correct the problem. Locate the Thermal Motor Reset button on the back of the vacuum. Press button and resume vacuuming.

Thermal Reset	
1. Unplug machine	3. Correct problem
2. Locate problem source (clogged hose or full bag)	4. Press reset button
If problem persists, consult owner's manual or contact retailer.	

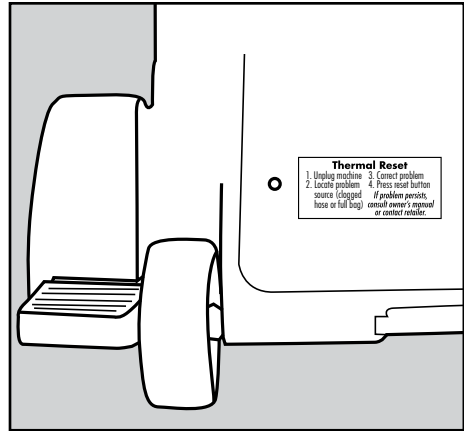

If problem continues, contact your Authorized Riccar Retailer.

## Trouble Shooting

<b>PROBLEM</b>	<b>POSSIBLE REASON</b>	<b>POSSIBLE SOLUTION</b>
Vacuum won't turn on	<ul style="list-style-type: none"><li>• Power cord not firmly plugged in</li><li>• Blown fuse or tripped breaker</li><li>• Needs service</li></ul>	<ul style="list-style-type: none"><li>• Plug unit in firmly</li><li>• Check house fuse or breaker. Replace fuse / reset breaker.</li><li>• Take to Authorized Retailer (1-888-6-RICCAR)</li></ul>
Vacuum won't pick up or low suction	<ul style="list-style-type: none"><li>• Vacuum bag full</li><li>• Clogged filter</li><li>• Hose clogged</li><li>• Worn brushroll</li><li>• Broken belt</li></ul>	<ul style="list-style-type: none"><li>• Install new bag</li><li>• Install new filter</li><li>• Remove obstacle</li><li>• Replace brush strips</li><li>• Replace belt</li></ul>
Dust escaping from vacuum	<ul style="list-style-type: none"><li>• Dust cover not installed properly</li><li>• Filter not installed correctly</li><li>• Vacuum bag not installed correctly</li></ul>	<ul style="list-style-type: none"><li>• Reinsert the dust cover and secure latch</li><li>• Review filter installation (page 20)</li><li>• Review bag installation (page 19)</li></ul>
<p>Any other service should be done by an Authorized Service Representative.</p> <p><b>Service 1-888-6-RICCAR</b></p> <p>To locate your nearest retailer, visit our website at <a href="http://www.riccar.com">www.riccar.com</a></p>		

# Warranty

---

## **What is Covered:**

This warranty covers any defects in material and workmanship in your new Riccar Vibrance vacuum.

## **How Long Coverage Lasts:**

Warranty coverage for Riccar Vibrance models VIBUSA, VIBCLNT and VIBCL lasts three years. Warranty coverage for Riccar Vibrance models VIB, VIBS, VIBD, VIBPNT and VIBP lasts four years. Warranty coverage for the Riccar Vibrance commercial models VIBCNT and VIBC lasts one year. Household models used commercially are only warranted for 90 days.

## **What is Not Covered:**

- Damage to the vacuum which occurs from neglect, abuse, alterations, accident, misuse or improper maintenance.
- Normal replacement items: disposable bags, disposable filters, light bulbs, belts and agitator brushes.
- Damage associated with or resulting from the use of non-genuine parts including normal replacement items.

## **What Riccar Vacuums Will Do:**

This warranty provides, at no cost to you, all labor and parts to keep this vacuum in correct operating condition during the warranted period.

## **How to Get Service:**

Warranty service can only be obtained by presenting the vacuum to an Authorized Riccar Retailer. A proof-of-purchase and product serial number will be required before service is rendered. **To locate your nearest Riccar Retailer, please call 1-888-6-RICCAR or visit the Riccar website at [www.riccar.com](http://www.riccar.com).**

THIS WARRANTY IS EXCLUSIVE AND IN LIEU OF ANY AND ALL OTHER WARRANTIES WHETHER WRITTEN, ORAL, EXPRESSED OR IMPLIED, (INCLUDING ANY WARRANTY OF MERCHANTABILITY OR FITNESS FOR A PARTICULAR PURPOSE). THIS WARRANTY DISCLAIMS LIABILITY FOR INCIDENTAL, OR CONSEQUENTIAL DAMAGES.

## **How State Law Applies:**

This warranty gives you specific legal rights, and you may also have other rights which vary from state to state.

Register your warranty on-line at [www.riccar.com](http://www.riccar.com)

# Owner's Warranty Information

---

*keep this for your records...*

Date of purchase \_\_\_\_\_

Serial number \_\_\_\_\_

Model number \_\_\_\_\_

**Purchased from:**

Store name \_\_\_\_\_

Address \_\_\_\_\_

City, State, Zip \_\_\_\_\_

Telephone \_\_\_\_\_

RICCAR®

RICCAR®  
[www.riccar.com](http://www.riccar.com)